

# ***Operating Instructions*** ***Spare Parts List***

---

## ***Wire saw SK-SD***

*Index 007*

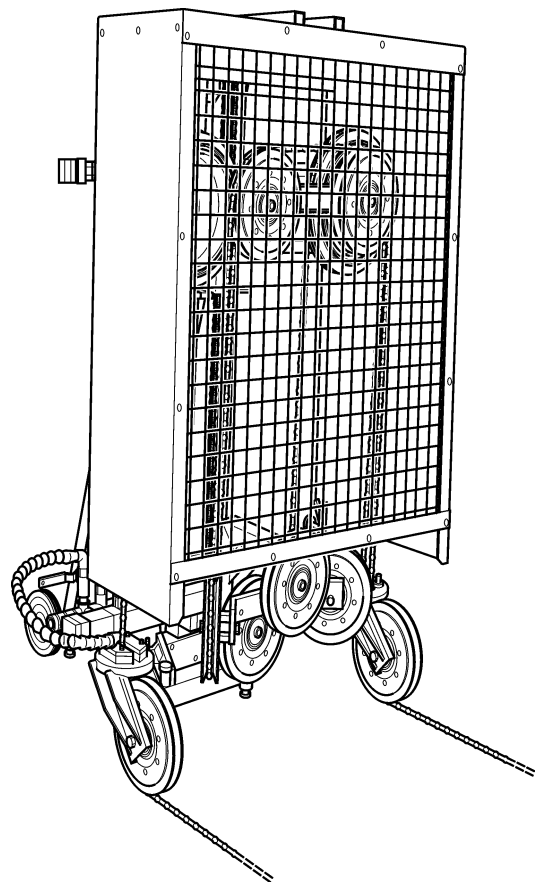

**Manufacturer's address:**

**TYROLIT Hydrostress AG  
Witzbergstrasse 18  
CH-8330 Pfäffikon  
Switzerland  
Phone +41 (0) 44 / 952 18 18  
Fax +41 (0) 44 / 952 18 00**

TYROLIT Hydrostress AG reserves the right to make technical changes without prior notice.

Copyright © 2005 TYROLIT Hydrostress AG, CH-8330 Pfäffikon ZH

All rights reserved, in particular the copying and translation rights.

The reprinting of these Operating Instructions, including extracts, is prohibited. No parts may be reproduced or processed, copied or distributed using electronic systems, in any form whatsoever, without the written permission of TYROLIT Hydrostress AG.

# Overview

	Page
<b>0 Introduction</b>	<b>1</b>
0.1 Congratulations!- - - - -	1
0.2 Validity of these Operating Instructions - - - - -	2
0.3 Standards - - - - -	2
0.4 Delimitation of the system - - - - -	2
0.5 Document structure - - - - -	3
<b>1 Product description</b>	<b>1</b>
1.1 Important information on the wire saw SK-SD - - - - -	1
1.2 Technical data - - - - -	4
<b>2 Safety instructions</b>	<b>1</b>
2.1 General- - - - -	1
2.2 Safety principles - - - - -	2
2.3 General safety rules - - - - -	3
2.4 Information and symbols- - - - -	4
2.5 Generally applicable warnings of residual dangers - - - - -	5
2.6 Responsibility - - - - -	6
<b>3 Design and function</b>	<b>1</b>
3.1 General- - - - -	1
<b>4 Assembly / disassembly</b>	<b>1</b>
4.1 Assembly / disassembly of the saw system - - - - -	1
4.2 Transport and place of installation - - - - -	3
4.3 Assembly wire saw SK-SD - - - - -	3
4.4 Removal wire saw SK-SD - - - - -	11
<b>5 Operation</b>	<b>1</b>
5.1 Operation wire saw SK-SD - - - - -	1
5.2 Troubleshooting - - - - -	7
5.3 Putting into operation - - - - -	8
<b>6 Servicing and Maintenance</b>	<b>1</b>
6.1 General- - - - -	1
6.2 Maintenance and servicing table - - - - -	3
6.3 Warranty - - - - -	8
6.4 Wearing parts - - - - -	9



# 0 Introduction

## 0.1 Congratulations!

You have decided to buy an advanced, tried and tested Hydrostress system and have thus acquired a highly sophisticated and reliable state-of-the-art unit.

Thanks to our efforts in the quality assurance area, your Hydrostress system is another top-of-the-range Swiss product:

- High performance
- Reliable operation
- High portability
- Easy handling
- Low maintenance costs

Only using original Hydrostress spare parts provides quality and interchangeability.

In the case of neglected or inappropriate maintenance, we will be unable to accept the warranty commitment as specified in our terms of delivery.

All repair work must be carried out by trained personnel only.

Should you need more details concerning your Hydrostress system in order to keep it in perfect condition, please contact our after-sales service for further information.

We hope that you will not experience any problems while working with your Hydrostress system.

### **TYROLIT Hydrostress AG**

Management

Copyright © Hydrostress, October 2006

**TYROLIT Hydrostress AG**  
**Witzbergstrasse 18**  
**CH-8330 Pfäffikon**  
**Switzerland**  
**Phone +41 (0) 44 / 952 18 18**  
**Fax +41 (0) 44 / 952 18 00**

## **0.2 Validity of these Operating Instructions**

These Operating instructions are just one part of the documentation accompanying the wire saw SK-SD. These Operating Instructions are supplemented by the "Wire saws Safety Manual / System Description", see document structure 0.5, 0-3.

This manual is only valid for the following system:

**Wire saw SK-SD**

## **0.3 Standards**

This Operating Manual has been prepared in accordance with CE Machinery Directive Appendix I and with the relevant standards in force at the time of printing.

## **0.4 Delimitation of the system**

These Operating Instructions describe the use of the wire saw SK-SD.

## 0.5 Document structure

The wire saw SK-SD documentation is structured as follows:

	Document
General system:	Wire saws Safety Manual / System Description
Machine	Operating Instructions / Spare parts list wire saw SK-SD
Components	Instruction leaflet

### 0.5.1 Wire saws Safety Manual / System Description

Hydrostress Machines and components have a modular design and can be assembled into various machine systems.

The “Wire saws Safety Manual / System Description” has been provided to help you operate the wire saw systems safely.

### 0.5.2 Operating Instructions / Spare parts list wire saw SK-SD

#### 0.5.2.1 Operating Instructions

These Operating Instructions describe the characteristics of the wire saw SK-SD only.



#### Information

These Operating Instructions are supplemented by the primary “Wire saws Safety Manual / System Description” documentation and by the documentation accompanying the product.

#### 0.5.2.2 Spare Parts List

The spare parts list is a standard part of the Operating Instructions.

### 0.5.3 Instruction leaflet

Instruction leaflets are used for system components that do not have their own Operating Instructions, but still require information to be provided for safe assembly or trouble-free operation.





# 1 Product description

## 1.1 Important information on the wire saw SK-SD

### 1.1.1 Description of the main components

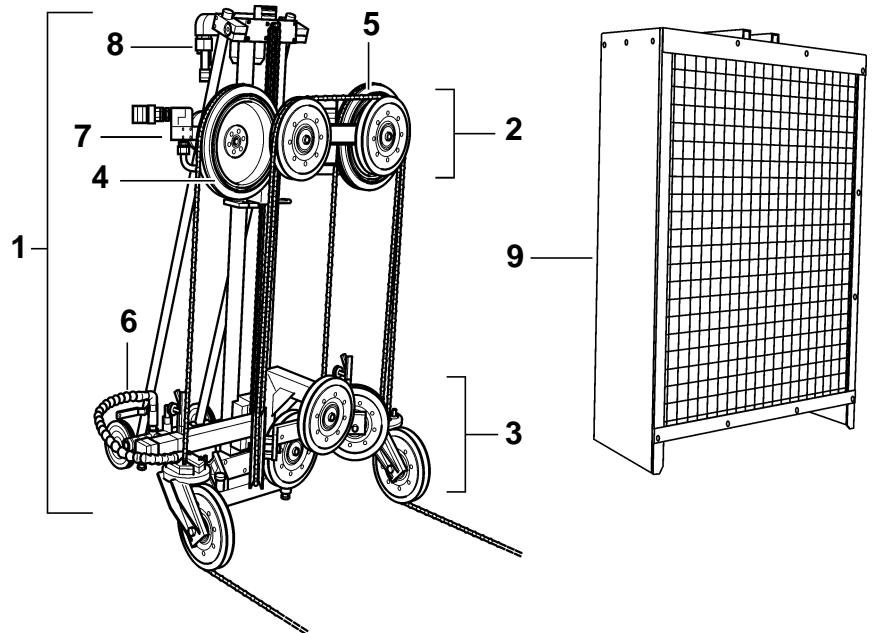

Fig. 1-1 Main components

- |                      |                      |
|----------------------|----------------------|
| 1 Drill rig BC-2     | 6 Water supply       |
| 2 Drive roll unit    | 7 Drive motor unit   |
| 3 Diverter roll unit | 8 Feed motor unit    |
| 4 Drive roll 1       | 9 Diamond wire guard |
| 5 Drive roll 2       |                      |



### Information

The wire saw SK-SD consists of drill rig BC-2 (No. 974266) and the wire saw kit SK-SD (No. 977084).

## 1.1.2 Application

The wire saw SK-SD is designed and built for the following application:

- Cutting concrete (including reinforced concrete) and natural stone, for other materials please contact us.
- Cutting of parting cuts, flush cuts and angle cuts in ceilings, floors or walls.
- The wire saw SK-SD should only be used and operated with the authorised anchoring systems.
- Only original TYROLIT cutting tools, diamond wire connectors and accessories should be used.

The applicable mandatory limitations on use and parameters are contained in Chapter 1 "Technical Data" 1.2, 1-4.

### 1.1.2.1 Safety measures

Any use other than for the intended purpose (see Chapter 1.1.2, 1-2) constitutes abuse or misuse.

## 1.1.3 Name plate

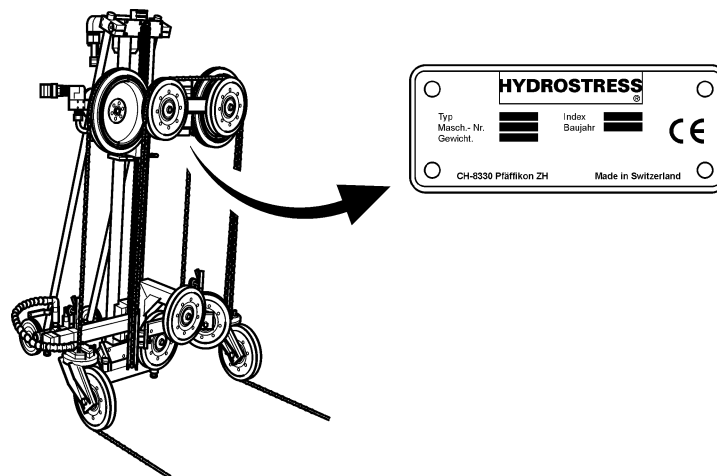

Fig. 1-2 Name plate

### 1.1.4 EC Declaration of Conformity

Description	Wire saw
Type designation	SK-SD
Year of construction	1994

We declare under our sole responsibility that this product complies with the following directives and standards:

#### 1.1.4.1 Directive applied:

EC Machinery Directive 98/37/EEC  
EC EMC Directives 89/336/EC

#### 1.1.4.2 Standards applied:

EN 12100-1	Safety of machines – basic concepts, general design principles.
EN 12100-2	
EN 294	Safety of machinery – Safety distances to prevent upper limbs reaching danger areas.
EN 349	Safety of machinery – Safety distances to avoid crushing of body parts.
EN 982	Safety of machines Safety requirements of safety systems and their components - Hydraulics.

TYROLIT Hydrostress AG



Roland Kägi  
Department Manager

## 1.2 Technical data

### 1.2.1 Dimensions

#### 1.2.1.1 Main dimensions

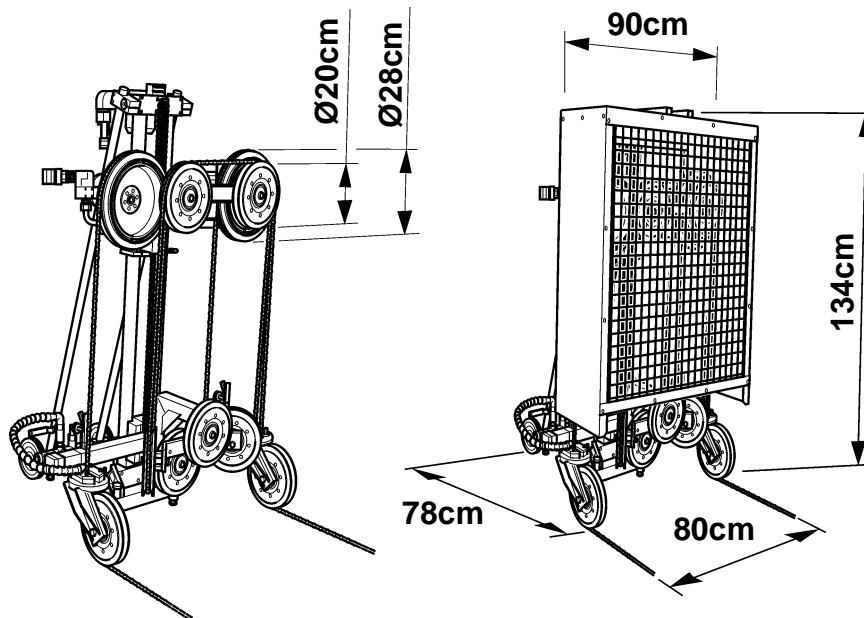

Fig. 1-3 Main dimensions

#### 1.2.1.2 Dowel dimension

The dowel dimension for anchoring the drill rig is 42 cm from the cutting line to the middle of the dowel space.

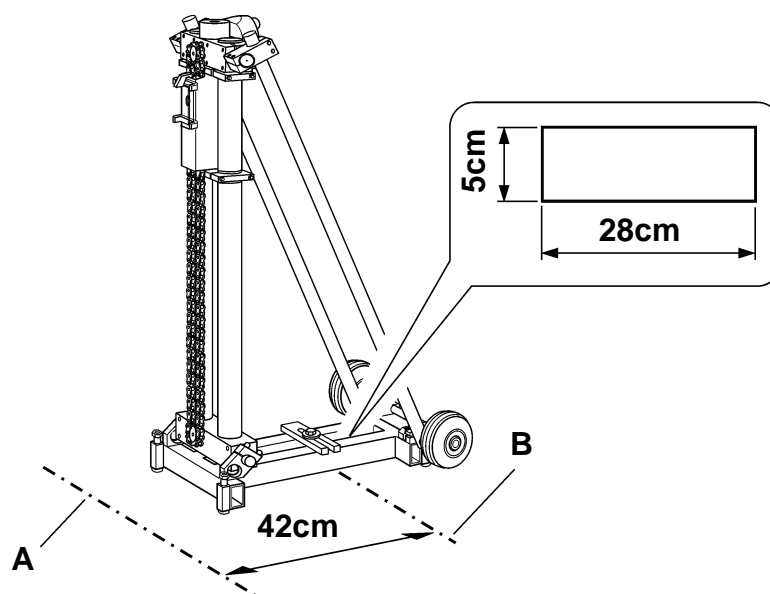

Fig. 1-4 Dowel dimension

- A Cutting line
- B Middle line of dowel space

### 1.2.2 Diamond wire



#### Information

Detailed information on the diamond wire and the diamond wire joining elements can be found in the diamond wire saw Safety Manual / System Description.

### 1.2.3 Wire guide



#### Information

Depending on the wire guide, the length of the stored diamond wire varies between 1.8 m and 4.0 m. Also, 1.5 m to 6.5 metres of wire is stored due to the stroke during the cut, depending on the wire guide.

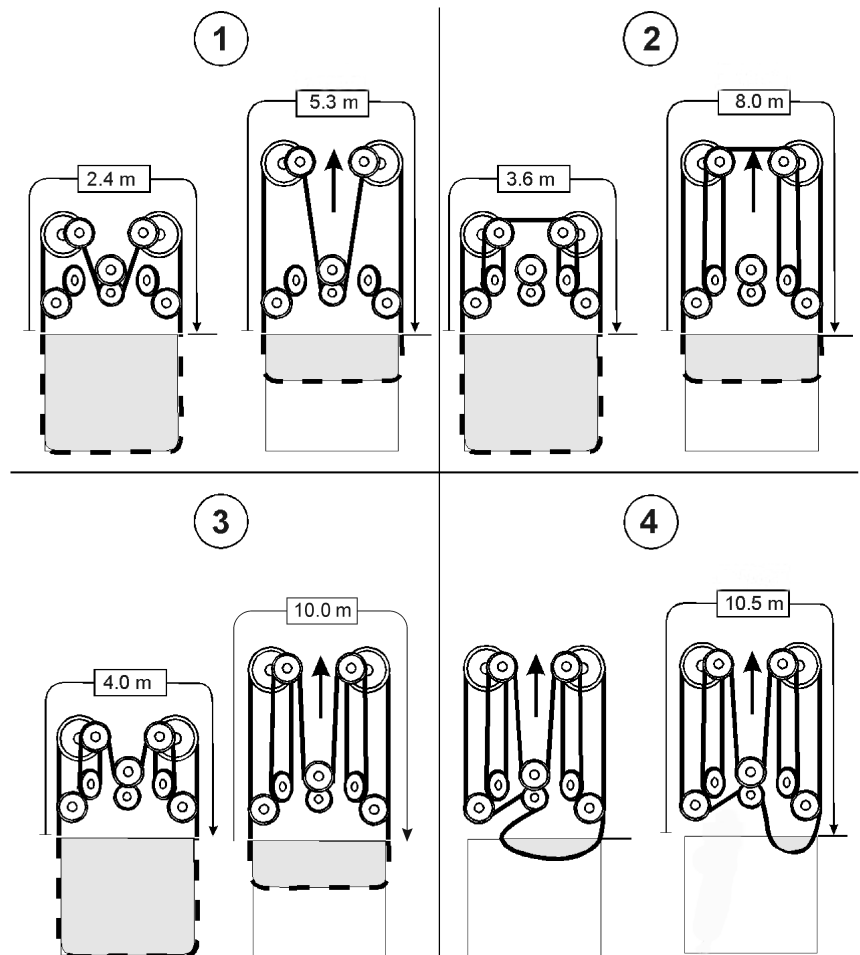

Fig. 1-5 Wire guide

### 1.2.4 Diamond wire lengths

#### 1.2.4.1 Wire length calculation

The minimum length of the wire results from:

$$L \text{ Total} = L1 + L2 + 0.5 \text{ m}$$

L1 = Circumference of main body - 0.8 m (width of saw system)

L2 = Length of stored wire at start of cut + 0.5 m

**Example:**

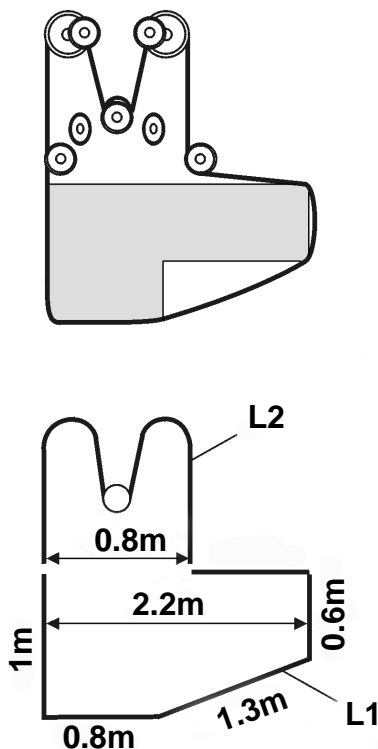

Fig. 1-6 Wire length calculation

$$L1 = 1\text{m} + 0.8\text{m} + 1.3\text{m} + 0.6\text{m} + 2.2\text{m} - 0.8\text{m} = \quad \mathbf{5.1 \text{ m}}$$

$$L2 = 2.4 \text{ m (wire guide variant 1)} + 0.5\text{m} = \quad \mathbf{2.9 \text{ m}}$$

$$L \text{ Total} = \quad \mathbf{8 \text{ m}}$$



#### Information

In order to be able to reap the benefits of the wire saw SK-SD, we recommend always using 1.5 m of diamond wire. This means that cuts of 0 to 9 m can be made on the main body without shortening the diamond wire.

### 1.2.5 Weights

#### 1.2.5.1 Weights of attachment parts

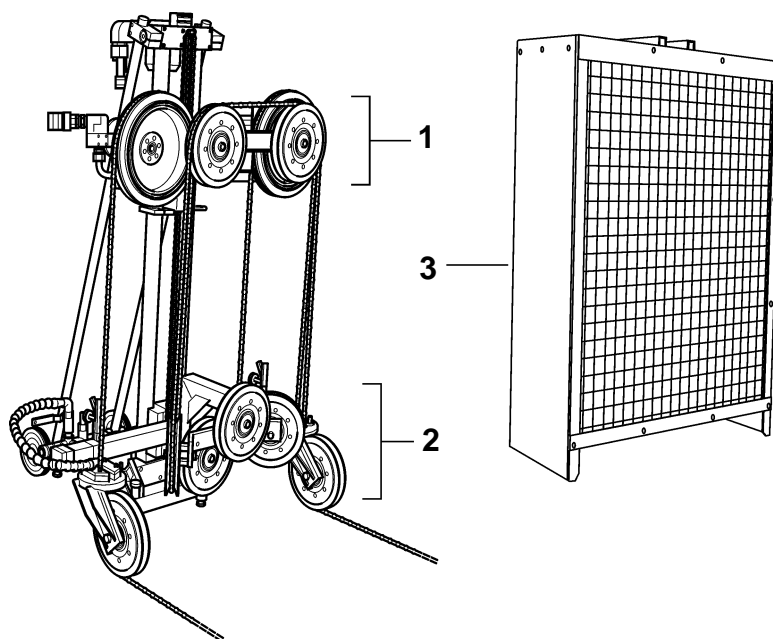

Fig. 1-7 Weights of attachment parts

1	Drive roller unit	26.85 kg
2	Diverter roll unit	35.35 kg
3	Diamond wire guard	11.55 kg

#### 1.2.5.2 Drill rig

Drill rig BC-2 1355	28.00 kg
---------------------	----------

### 1.2.6 Feed motor unit

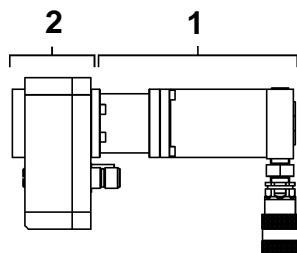

Fig. 1-8 Feed motor unit

- 1 Feed motor with mounting flange and coupling Article no. 977584
- 2 Feed transmission (1:8.6 and 1:2.2) Article no. 974263

### 1.2.7 Drive motor unit

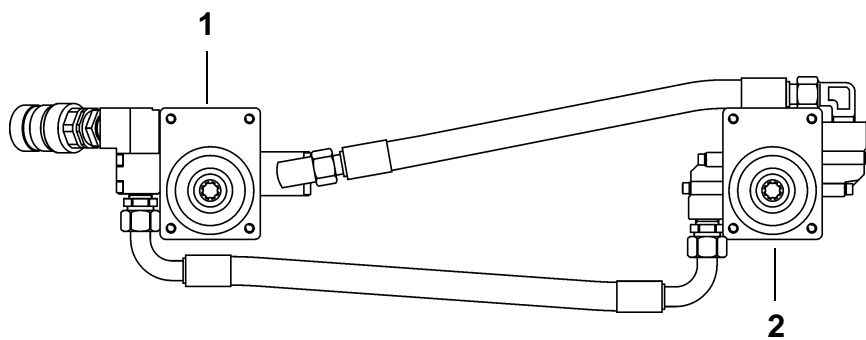

Fig. 1-9 Drive motor unit

- 1 Drive motor I
- 2 Drive motor II



<b>Information</b>	
Four motor units are available for the wire saw SK-SD with different capacities (19ccm / 27ccm / 33ccm / 41ccm).	

Drive motor unit		Capacity	Article no.
Drive motor I	Drive motor II		
11 ccm	30ccm	41 ccm	980680
11 ccm	22ccm	33 ccm	980679
8 ccm	19ccm	27 ccm	976655
8 ccm	11ccm	19 ccm	977235



### 1.2.8 Cutting speed:

The cutting speed is determined by the drive unit and the motor unit.

Wire speed in m/s				
Drive unit output	Hydraulic motor unit			
	19ccm	27ccm	33ccm	41ccm
30 l/min	21	-	-	-
33 l/min	24	-	-	-
40 l/min	29	20	-	-
45 l/min	-	23	19	-
46 l/min	-	23	19	-
47 l/min	-	24	19	-
50 l/min	-	25	21	-
57 l/min	-	29	24	19
60 l/min	-	31	25	20
61 l/min	-	-	25	21
70 l/min	-	-	29	24
76 l/min	-	-	31	26
80 l/min	-	-	33	27
90 l/min	-	-	-	31



Information
<p>The cutting speed must be selected according to the nature of the material.</p> <p>The recommended values are:</p> <p>20 -25 m/s for granite, marble, old concrete with or without reinforcement</p> <p>25 - 30 m/s for abrasive materials, fresh concrete, asphalt, sandstone</p> <p><b>The maximum permissible cutting speed for TYROLIT diamond wires is 35 m/s.</b></p>

### 1.2.9 Water connection

Pressure: min. 1 bar to max. 6 bar  
 Quantity: min. 4 l/min.  
 Temperature: 25°C

### 1.2.10 Connectable drive units



#### Information

The wire saw SK-SD must only be operated with TYROLIT Hydrostress AG drive units. Obtain advice from TYROLIT Hydrostress AG when selecting the drive unit.

### 1.2.11 Noise exposure (noise level)

Depending on the working environment, the wire saw SK-SD can cause excessive noise during operation.

Noise level 75dB  
 Sound pressure 85dB

The noise can cause permanent harm to the hearing of operating personnel and of other people nearby within a short time.

**Ear protectors must therefore always be worn while working.**



#### Danger

**Noise danger.**

**When using the wire saw SK-SD hearing protection must be worn.**

**If this instruction is not followed irreparable hearing damage may result.**

## 1.2.12 Tool chest

**Tool chest with contents                      Part number 975746**

**Tool chest excluding contents            Part number 973801**

### 1.2.12.1 Tool chest contents

Quan.	Description	Part Number
1	Fork wrench, size across flats 41	973779
1	Fork wrench, size across flats 36	973777
1	Ring fork wrench, size across flats 24	973786
1	Ring fork wrench, size across flats 19	973784
1	Allen key, size across flats 4	973790
1	Allen key, size across flats 5	973791
1	Allen key, size across flats 6	973792
1	Allen key, size across flats 8	973793
1	Screwdriver size 5	973803
10	Drive-in dowel	971622
1	Dowel iron	977153
1	1250g steel hammer	973770
1	Tension spindle fixing point	977619
2	Hose nipple	972788
1	Chain lock	972480
1	Grease gun	975056
1	Spare cartridge	975057
5	Support ring	974984
1	Ear plugs	977224



## 2 Safety instructions



### Information

The safety instructions for the wire saw SK-SD are supplemented by the safety instructions of the "Diamond wire saws Safety Manual /System Description".  
No work should be performed on or with the wire saw system until the safety instructions in the wire saw Operating Instructions and the Safety Manual / System Description have been read and understood.

### 2.1 General

#### 2.1.1 Target audience

This chapter describes the safety instructions that are essential to follow when using the wire saw SK-SD.

All persons who work on and with the wire saw SK-SD have a duty to read and understand the chapters of the Operating Instructions relevant to their particular activities and the Diamond wire saws Safety Manual /System Description.

This applies in particular to the "Safety instructions" chapter which is mandatory for all persons and activities.

#### 2.1.2 Observance of the safety instructions

No work must be performed on or with the wire saw SK-SD before the safety instructions contained in the Operating Instructions (Chapter 2) have been read and understood. The Operating Instructions are mandatory for all work – abridged instructions should only be used in the form of checklists.

The wire saw SK-SD has been inspected before being shipped and is delivered in perfect condition. TYROLIT Hydrostress AG does not accept any liability for damage which is caused by failure to observe the instructions and information provided in the Operating Instructions. This applies in particular to:

- Damage caused by improper use and operator error.
- Damage caused by failure to observe safety-related information in the Operating Instructions and the Diamond wire saws Safety Manual / System Description or shown on the warning signs fitted to the machine.
- Damage caused by defective or neglected maintenance work.

Independently performed conversions and alterations may affect safety and are not permitted.

#### 2.1.3 Use for intended application

The intended application is described in "Chapter 1" under 1.1.2,  1-2.

### **2.1.4 Observance of the information on workplace safety and danger area**

Descriptions of the workplace and danger areas are provided in the Diamond wire saws Safety Manual / System Description.

## **2.2 Safety principles**

### **2.2.1 Delimitation of the safety concept**

The wire saw SK-SD has no effect on the safety concept of the connected systems, apparatus and installations.

### **2.2.2 Safety elements**

Protection from personal injury is based primarily on a safety concept and design safety.

#### **2.2.2.1 Passive safety elements**

##### **Protection from live electrical parts**

All functional units containing parts which carry hazardous voltages are shock-protected by suitable covers.

### **2.2.3 Removal of protective devices**

Protective devices may only be removed if the unit has been switched off, disconnected from the mains and is at a standstill. Safety components, in particular, may only be removed and refitted by authorised personnel, see "Chapter 2" 2.6.1, 2-6.

Before using the wire saw SK-SD again, the safety elements must be checked for correct operation.

### **2.2.4 Safety measures (organisational)**

#### **2.2.4.1 Product monitoring obligation**

Operating personnel must notify changes in operational behaviour or safety-related components to a responsible person or the manufacturer, immediately.

#### **2.2.4.2 Location of the Operating Instructions**

A copy of the Operating Instructions must be available at all times to staff at the place of use of the apparatus.

## **2.3 General safety rules**

### **2.3.1 Statutory provisions**

The generally applicable national and local safety and accident prevention provisions and the supplementary operator regulations must be followed and complied with.

### **2.3.2 Inspection and maintenance obligation**

The operator is under an obligation to only use the wire saw SK-SD when it is in a perfect and undamaged condition. The maintenance intervals listed in the Operating Instructions must be adhered to without fail. Malfunctions and mechanical damage must be rectified without delay.

### **2.3.3 Spare parts**

Only original spare parts should be used. Otherwise damage may be caused to the wire saw SK-SD or to other property and persons.

### **2.3.4 Power connections**

The wire saw SK-SD must be connected and coupled to the drive unit used in accordance with the Operating Instructions.

### **2.3.5 Modifications**

No technical alterations should be made to the apparatus in the form of additions or conversions without the written consent of TYROLIT Hydrostress AG.

### **2.3.6 Safety instructions in the individual chapters**

The chapters of these Operating Instructions contain additional safety instructions. These make reference to specific potential dangers (residual dangers). The instructions must be followed closely and require that the actions described are taken.

## 2.4 Information and symbols

In these Operating Instructions information panels are used to draw attention to residual dangers and to point out important technical requirements.

### 2.4.1 Hazard symbols in the Operating Instructions



#### **Danger**

Warning of danger, where failure to comply could lead to death or serious injury.



#### **Warning**

Warning of danger, where failure to comply could lead to injury or damage to property.

Fig. 2-1 Danger and warning notices

### 2.4.2 Information symbol



#### **Information**

Text displayed in this way is practical information and is aimed at achieving optimum use of the installation or apparatus. Failure to take note of this information may mean that the performances shown in the technical data can no longer be guaranteed.

Fig. 2-2 Information notice



## 2.5 Generally applicable warnings of residual dangers

In the following warnings of residual dangers are shown that are generally applicable to all work with and on the wire saw SK-SD and during all phases of the life of the wire saw SK-SD.



### Warning

**Danger from sharp edges on cutting tool (diamond wire).**

**When touching tools at a standstill it is recommended that protective gloves are worn.**

**Failure to adhere to this regulation may result in cut wounds to the hands.**

## **2.6 Responsibility**

### **2.6.1 Authorised personnel**

All work on or with TYROLIT Hydrostress AG machines or systems must be performed by authorised personnel. Personnel are considered by TYROLIT Hydrostress AG to be authorised if they meet the necessary training and know-how requirements and they have been assigned a precise functional role.

The personnel qualifications for the corresponding work are contained in the introduction under "General" of the respective chapters.

### **2.6.2 Delimitation of authority (functional roles)**

#### **2.6.2.1 The manufacturer**

TYROLIT Hydrostress AG or a company expressly nominated by TYROLIT Hydrostress AG is deemed to be the manufacturer of the products supplied by TYROLIT Hydrostress AG. Within the context of an integrated quality assurance and safety control system, the manufacturer is entitled to request information about the products from the operator.

#### **2.6.2.2 Operator**

The operator named by TYROLIT Hydrostress AG is the primary, legal entity responsible for the designated correct use of the product and for the training and assignment of the authorised personnel. The operator sets out the mandatory skills and level of training of the authorised personnel for his company.

### **2.6.3 Operator (user)**

User is the term employed by TYROLIT Hydrostress AG to designate a person who independently performs the following work:

- Sets up TYROLIT Hydrostress AG machines or systems for tasks according to the intended purpose.
- Performs tasks independently and monitors these.
- Locates malfunctions and initiates or performs troubleshooting.
- Carries out servicing and simple maintenance.
- Monitors the correct functioning of the safety devices.

### **2.6.4 Service engineers**

Service engineer is a term used by TYROLIT Hydrostress AG to designate a person who independently performs the following work:

- Installs TYROLIT Hydrostress AG machines and systems and controls their correct application.
- Makes adjustments to machines and systems for which special access rights are required.
- Performs repairs, complex service work and maintenance work.

## **2.6.5 Qualification and training**

### **2.6.5.1 Operator**

- Trained building expert in a management position.
- Has relevant experience in personnel management and danger assessment.
- Has read and understood the "Safety instructions" chapter.

### **2.6.5.2 Operator (user)**

- Has trained as a concrete cutting expert or completed a technical course from the regional professional association and federation or has professional experience.
- Has received an introduction (basic training) to the operation of the wire saw SK-SD from a service engineer.
- Has read and understood chapter 2 "Safety instructions".

### **2.6.5.3 Service engineers**

- Has specialist professional training (mechanical / electrotechnical).
- Has attended specialist courses at TYROLIT Hydrostress AG.
- Has read and understood the "Safety instructions" chapter.



### 3 Design and function

#### 3.1 General

The wire saw SK-SD is assembled from various components to form a complete wire saw system.

##### 3.1.1 System components

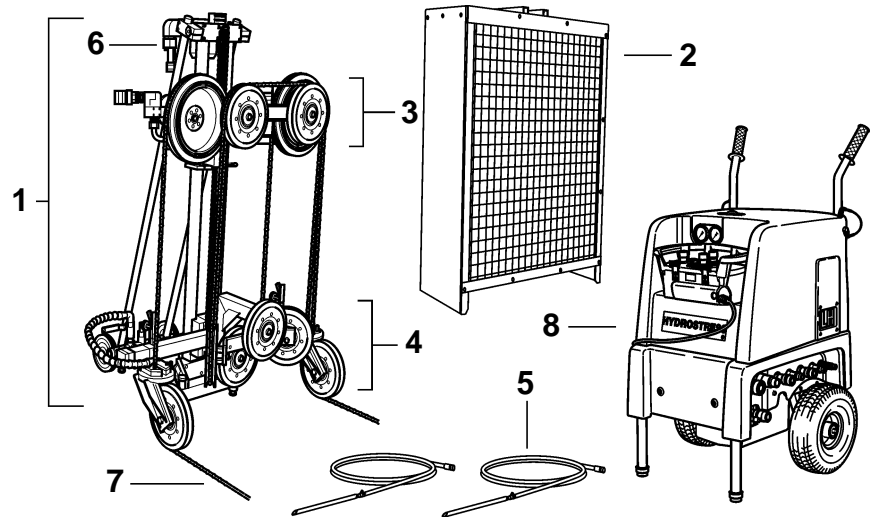

Fig. 3-1 System components

- |                      |                        |
|----------------------|------------------------|
| 1 Drill rig BC-2     | 5 Water lances         |
| 2 Diamond wire guard | 6 Feed motor           |
| 3 Drive roll unit    | 7 Diamond wire         |
| 4 Diverter roll unit | 8 Hydraulic drive unit |



#### Information

The layout and functions of the saw system are described in the "Safety Manual / System Description for Wall Saws".

### 3.1.2 Drill rig BC-2

#### 3.1.2.1 Design

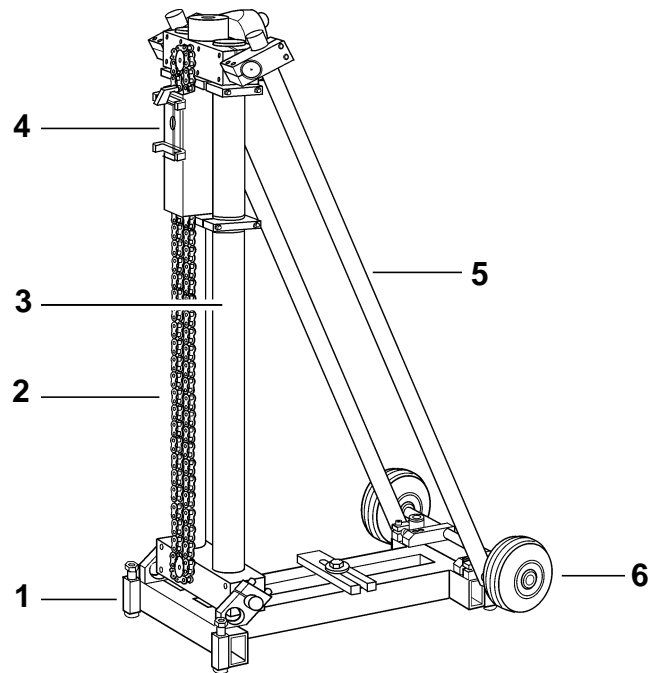

Fig. 3-2 Drill rig BC-2

- 1 Chassis
- 2 Chain
- 3 Guide columns
- 4 Support
- 5 Support rod
- 6 Undercarriage (option)



#### Information

Information about the components can be found in the Operating Instructions of the BC-2 drill rig.

#### 3.1.2.2 Function

Holes for diamond wire saw work can be drilled with the BC-2 drill rig supplemented by the drill motor and drill bit. By means of the wire saw kit the BC-2 drill rig is converted to the wire saw SK-SD.

### 3.1.3 Diamond wire guard

#### 3.1.3.1 Design

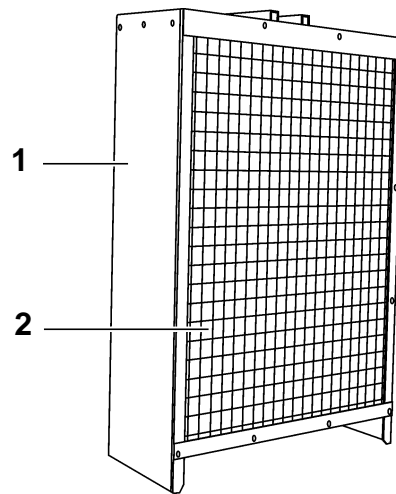

Fig. 3-3 Diamond wire guard

- 1 Metal guard
- 2 Guard mesh

#### 3.1.3.2 Function

The diamond wire guard is a safety device. It prevents contact with the diamond wire when it is motion, intercepts flying parts and thus reduces the risk of injury. At the same time, the wire guard acts as a spray guard.

### 3.1.4 Drive roller unit

#### 3.1.4.1 Design

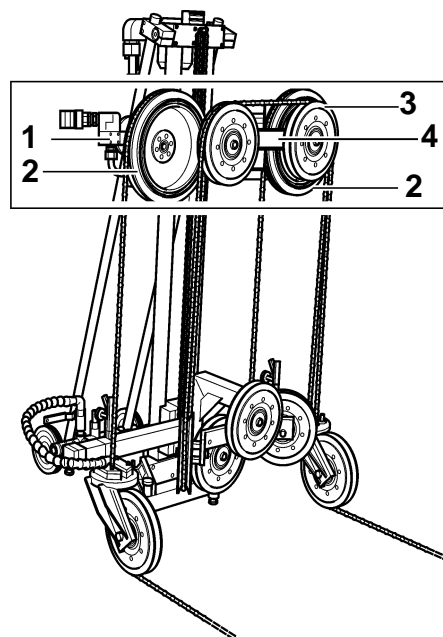

Fig. 3-4 Drive roller unit

- 1 Drive motor
- 2 Drive roll  $\varnothing$  280mm
- 3 Diverter roll  $\varnothing$  200mm
- 4 Support

#### 3.1.4.2 Function

The diamond wire is driven using two hydraulic motors via the two drive rolls. The twin drive unit also serves as a tensioning element in the diamond wire storage.



### 3.1.5 Diverter roll unit

#### 3.1.5.1 Design

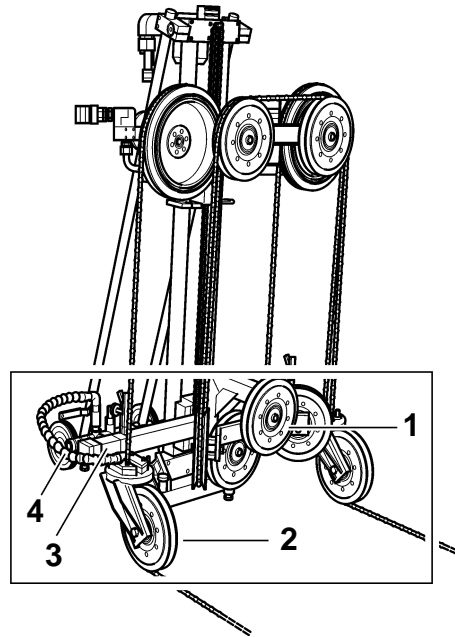

Fig. 3-5 Diverter roll unit

- 1 Diverter roll  $\varnothing$  200mm
- 2 Swivel roll  $\varnothing$  200mm
- 3 Support
- 4 Water connections and water line

#### 3.1.5.2 Function

The diverter roll unit serves the diamond wire guidance and the diamond wire storage.  
The water connection and the water distribution of the wire saw SK-SD are located on the diverter roll unit.

### 3.1.6 Water lances

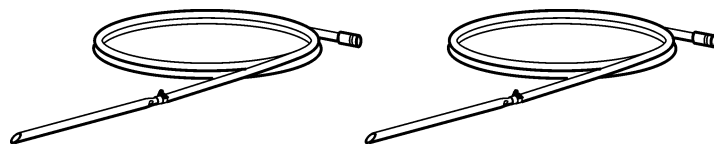

Fig. 3-6 Water lances

#### Function

Water lances are used to convey water to the point where the diamond wire enters the cut.

### 3.1.7 Feed motor with gearbox

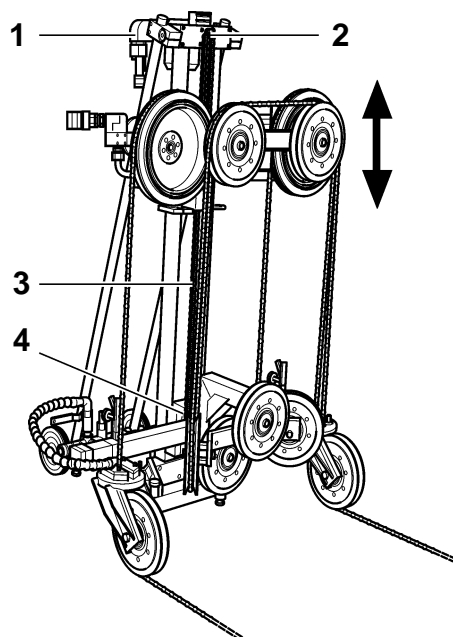

Fig. 3-7 Feed motor

- 1 Feed motor
- 2 Drive pinion
- 3 Link chain
- 4 Diverter pinion

#### Function



With the aid of the feed motor, the drive unit of the wire saw SK-SD can be driven up and down via a link chain. The feed motor is connected to the drive unit. The feed direction and the feed speed can be set on the drive unit.

## 4 Assembly / disassembly

### 4.1 Assembly / disassembly of the saw system



#### Information

In order to be able to use the wire saw SK-SD correctly (see "Chapter 1" 1.1.2, ) 1-2), it must have other system components added in order to form a complete saw system (see "Chapter 3" 3.1.1, ) 3-1).

#### 4.1.1 General

Before proceeding, first of all read Chapter 2 "Safety instructions",  2-1 in these Operating Instructions. Be sure also to take note of all the danger information given here and follow the instructions on how to avoid physical injury and damage to property.

#### 4.1.2 Safety instructions

It is essential to observe the following safety instructions, in particular in relation to the assembly/disassembly of the wire saw SK-SD.



#### Danger

**Danger of falling heavy parts.**

**When performing the types of work described in this chapter, it is absolutely essential to wear the following personal protective equipment: helmet, goggles, protective gloves and safety shoes.**

**It is essential that the work instructions and procedures described in these Operating Instructions are followed.**

**Failure to observe this regulation may lead to serious physical injury, possibly even death, and to property damage.**



## Warning

**Danger from uncontrolled movements of the wire saw SK-SD!**

**Never connect or disconnect hoses when the wire saw SK-SD is running.**

**Failure to observe this regulation may result in cut wounds or injury to body parts as well as damage to property.**

### 4.1.3 Personnel qualifications

- Has trained as a concrete cutting expert or completed a technical course from the regional professional association and federation or has professional experience.
- Has received an introduction (basic training) to operation of the wire saw SK-SD from a service engineer.
- Has read and understood chapter 2 "Safety instructions".

## 4.2 Transport and place of installation

The wire saw SK-SD is a high-tech apparatus. The wire saw SK-SD must be transported in such a way that it is not damaged in transit. Where suitable means of transport are available, these must be used.

**Do not place any items on the Wire saw SK-SD during transport!**



### Information

The wire saw SK-SD should be carried carefully, by two people if possible to prevent spinal damage and accidents.

## 4.3 Assembly wire saw SK-SD



### Information

Before connecting the wire saw SK-SD to the control unit, the wire saw SK-SD must be set up and aligned with the object to be cut.

Always proceed as follows:

- Secure the BC-2 drill rig to the floor surface
- Assemble the wire saw kit SK-SD
- Align the wire saw SK-SD on the object to be cut
- Position diamond wire
- Set up and connect water supply
- Mounting the diamond wire guard
- Connect the drive unit

### 4.3.1 Assemble the wire saw kit SK-SD

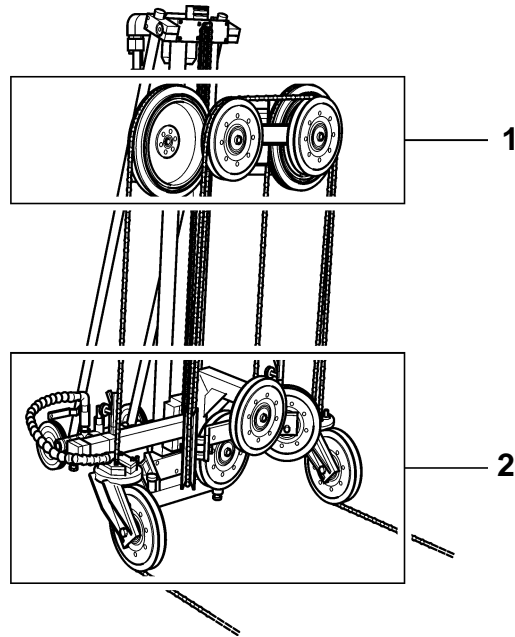

Fig. 4-1 Drive and diverter roll unit

#### Proceed as follows:

- Assemble the drive roll unit (1)
- Assemble the diverter roll unit (2)



## Warning

Risk of accident through tipping of the BC-2 drill rig.

Secure the drill rig before mounting the drive roll unit and the diverter roll unit, so that the drill rig cannot tip over.

Failure to adhere to this regulation may result in physical injury and damage to property.

### 4.3.2 Mount the drive motor

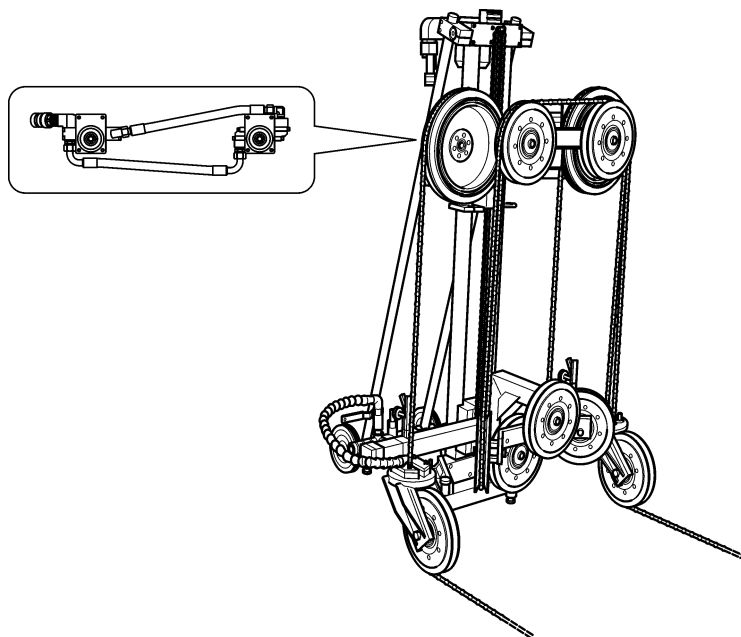

Fig. 4-2 Mount the drive motor

#### Proceed as follows:

- Push the drive shafts of the drive motors onto the toothed profile couplings of the drive rolls
- Tighten the drive motors with the Allen screws (width across flats 6)



#### Information

For the Wire saw SK-SD the TYROLIT Hydrostress AG has complete motor units with different power levels. Information about the motor units can be found in "Chapter 1" 1.2.7, 1-8.

### 4.3.3 Wire saw SK-SD Set-up

The following points must be taken into consideration during the alignment and set-up of the wire saw SK-SD:

- Danger and working areas for wire saw work:  
see safety manual / system description for diamond wire saws
- Diamond saw guidance and securing  
see safety manual / system description for diamond wire saws
- Taut and slack side of diamond wire:  
see safety manual / system description for diamond wire saws
- Cutting force:  
see safety manual / system description for diamond wire saws
- Water supply and water set-up:  
see safety manual / system description for diamond wire saws
- Diamond wire direction of travel:

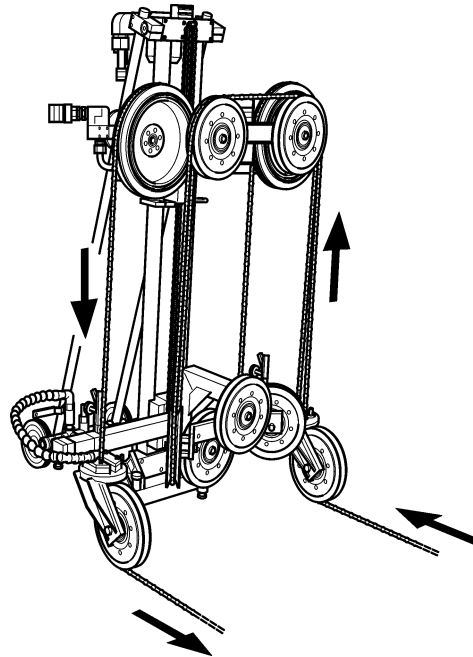



Fig. 4-3 Direction of travel



### 4.3.4 Inserting / storage of diamond wire



<b>Warning</b>	
	<p><b>Danger from sharp edges on cutting tool (diamond wire).</b></p> <p><b>When touching tools at a standstill it is recommended that protective gloves are worn.</b></p> <p><b>Failure to adhere to this regulation may result in cut wounds to the hands.</b></p>

#### 4.3.4.1 Preparation of "diamond wire"





<b>Information</b>	
	<p>Information on the design and for the correct handling of the diamond wire can be found in the Diamond wire saws Safety Manual / System Description.</p>



<b>Information</b>	
	<p>The diamond wire can be inserted into the wire saw SK-SD open or closed.</p>

#### 4.3.4.2 Diamond wire storage possibilities



<b>Information</b>	
	<p>Information about wire guidance and storage can be found in "Chapter 1" 1.2.3,  1-5.</p> <p>Information about diamond saw lengths can be found in "Chapter 1" 1.2.4,  1-6.</p>

### 4.3.5 Set up and connect water supply

Water is used for cooling the cutting tool. In order to ensure guaranteed cooling and flushing of the diamond wire, the swivel rollers and the entry points of the diamond wire in the cut must be sprayed with water.

Connecting the water supply

- Water pressure:                   min. 1 bar  
  max. 6bar
- Water temperature:               max. 25°C



<b>Information</b>	
	When working with diamond wire saw systems ensure that the water feed is not interrupted or shut off. Correct flushing with water will allow you to extend the lifetime of your diamond saw significantly.



<b>Information</b>	
	Detailed information about setting up, collecting and disposing of water can be found in the Diamond Wire Saw Safety Manual / System Description.
	Dry cutting is possible with a suitable diamond wire saw and after consulting TYROLIT Hydrostress AG.

### 4.3.6 Mounting the diamond wire guard

The diamond wire guard is a safety device that prevents accidental contact with the tool, intercepts flying parts and at the same time acts as a spray guard.

**When working with the wire saw SK-SD the diamond wire guard must always be fitted.**

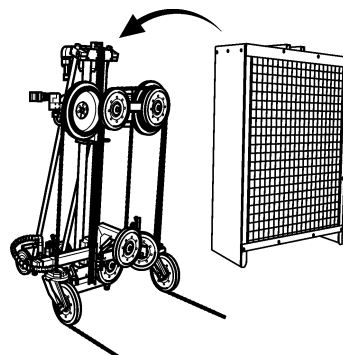

Fig. 4-4 Mounting the diamond wire guard

## 4.3.7 Wire saw SK-SD Connect to the drive unit

### 4.3.7.1 Fundamentals

- Clean the couplings regularly
- Connect together both ends of any hoses, which are not used, so that the couplings are protected
- Always switch off the drive unit and relieve the pressure in the hoses before handling the wire saw SK-SD



#### Information

If hoses cannot be connected or are difficult to connect, they are under pressure. Depressurise the hoses by means of the pressure relief device.

**Never use force to connect couplings!**

### 4.3.7.2 Releasing pressure in the hose

1. Hoses that are coupled to the drive unit:  
(see drive unit Operating Instructions)
2. Hoses that are not coupled:  
Position pressure relief device on hose on the coupling and screw in

### 4.3.7.3 Hose connections

#### Proceed as follows:

- Visual inspection  
Check:
  - Oil leaks from hoses and couplings
  - Couplings for damage and contamination
  - Hoses for damage
- Push the hose coupling on to its counterpart until you hear it "click"
- Twist the locking ring of the coupling



#### Information

Connect the hose couplings with angle pieces to the wire saw SK-SD. Connect the straight hose couplings to the drive unit.

The following hose connections must be established:

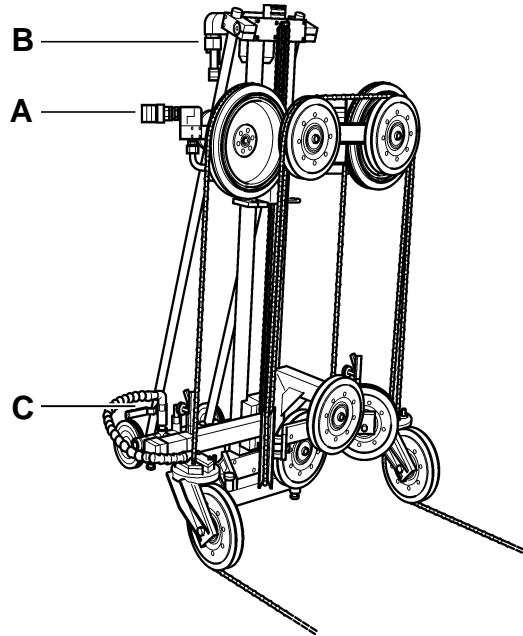

Fig. 4-5 Hose connections

Hoses wire saw SK-SD	Drive unit hoses
<p><b>Diamond wire drive motor (A):</b></p> <p>Main circuit oil return Coupling – male connector</p> <p>Main circuit oil flow Coupling – female connector</p>	<p>Main circuit oil return Coupling – female connector</p> <p>Main circuit oil flow Coupling – male connector</p>
<p><b>Feed motor travelling motion (B):</b></p> <p>Feed circuit Coupling – male connector</p> <p>Feed circuit Coupling – female connector</p>	<p>Feed circuit Coupling – female connector</p> <p>Feed circuit Coupling – male connector</p>
<p><b>Water (C):</b></p> <p>Water inlet Coupling – male connector</p>	<p>Water outlet Coupling – female connector</p>

## 4.4 Removal wire saw SK-SD

### 4.4.1 Disconnect the wire saw SK-SD from the system

#### Fundamentals

- Keep hose couplings clean and never allow them to drop
- Always switch off the drive unit and relieve the pressure in the hoses before handling the wire saw SK-SD
- Do not uncouple hoses at the drive unit end; the pressure can then be reduced via the drive unit
- Do not leave hoses in the sun  
(Pressure build-up through oil expansion)



#### Information

If hoses cannot be connected or are difficult to connect, they are under pressure. Depressurise the hoses by means of the pressure relief.

**Never use force to connect couplings!**

#### 4.4.1.1 Releasing pressure in the hose

1. Hoses that are coupled to the drive unit:  
(see drive unit Operating Instructions)
2. Hoses that are not coupled:  
Position pressure relief device on hose on the coupling and screw in

### 4.4.2 Dismantling the wire saw SK-SD

Always proceed as follows:

- Disassemble the diamond wire guard
- Move drive roll unit to start position
- Remove the diamond wire
- Disconnect the wire saw SK-SD from the system,  
see "Chapter 4" 4.4.1, 4-11  
Disconnect hose connections  
see "Chapter 4" 4.4.2.3, 4-12
- Disassemble the wire saw kit
- Disconnect drill rig fastening

#### 4.4.2.1 Disassemble the diamond wire guard

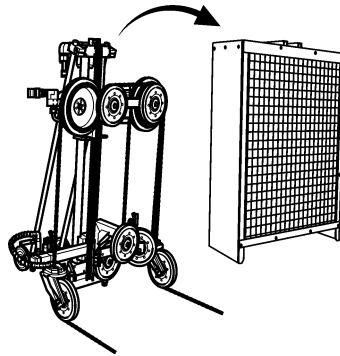

Fig. 4-6 Disassemble the diamond wire guard

#### 4.4.2.2 Remove the diamond wire

### Warning



**Danger from sharp edges on cutting tool (diamond wire).**

**When touching tools at a standstill it is recommended that protective gloves are worn.**

**Failure to adhere to this regulation may result in cut wounds to the hands.**



### Information

The diamond wire can be pulled out of the wire saw SK-SD open or closed.

#### 4.4.2.3 Detach hose connections

Proceed as follows when disconnecting hydraulic and water hoses:

- Rotate locking ring
- Hold hose straight
- Slide back coupling sleeves
- Pull off hose

#### 4.4.2.4 Disassemble the wire saw kit



### Warning

**Risk of accident through tipping of the BC-2 drill rig.**

**Loosen the drill rig fixing only after disassembling the wire saw kit.**

**Failure to adhere to this regulation may result in physical injury and damage to property.**







## 5 Operation

### 5.1 Operation wire saw SK-SD



#### Information

In order to be able to use the wire saw SK-SD correctly (see "Chapter 1" 1.1.2,  1-2), it must have other system components added in order to form a complete saw system (see "Chapter 3" 3,  3-1).

In order for you to be able to safely operate the wire saw SK-SD in the saw system, you must first read the Safety Manual / System Description for diamond wire saws.

#### 5.1.1 General

Before proceeding, first of all read Chapter 2 "Safety instructions",  2-1 in these Operating Instructions. Be sure also to take note of all the danger information given here and follow the instructions on how to avoid physical injury and damage to property.

#### 5.1.2 Safety instructions

It is essential to observe the following safety instructions, in particular in relation to the operation of the wire saw SK-SD.



#### Danger

**Danger from diamond wire breaks. If the diamond wire breaks the whiplash effect can lead to throwing of the free wire length. When there is a whiplash effect individual diamond wire beads or entire connectors may also come loose and fly through the air at great speed.**

**Always work with the protective devices fitted. Always observe the safety distances and working areas stated in the Diamond wire saws Safety Manual / System Description.**

**During sawing operations no persons should remain in the danger area.**

**Failure to observe this regulation may lead to serious physical injury, possibly even death, and to property damage.**

### Danger



**Danger from machine suddenly starting up.**

**Before switching on the system the operator must ensure that no other person is present in the danger areas. If the system is left unattended it must be switched off and secured against being powered up again.**

**Failure to adhere to this regulation may result in crushing or cut wounds to body parts and damage to property.**

### Danger



**Hazard from falling building structures.**

**The building structure must be correctly secured (see Operating Instructions in the Diamond wire saws Safety Manual / System Description).**

**Failure to observe this regulation may lead to serious physical injury, possibly even death, and to property damage.**

### Danger



**Noise danger.**

**When using diamond wire saw systems hearing protection must be worn.**

**If this instruction is not followed irreparable hearing damage may result.**

### Warning



**When handling diamond wire and wire rolls there is a danger of fingers being crushed.**

**When grinding-in the diamond wire sufficient clearance between the hands and the rolls or the structure must always be ensured. The feed motors must not be started if the diamond wire is still being touched.**

**Failure to adhere to this regulation may lead to crushing or cut wounds to body parts.**

### 5.1.3 Personnel qualifications

- Has trained as a concrete cutting expert or completed a technical course from the regional professional association and federation or has professional experience.
- Has received an introduction (basic training) to operation of the wire saw SK-SD from a service engineer.
- Has read and understood chapter 2 "Safety instructions".

## 5.1.4 Controls

### 5.1.4.1 Drive unit

The wire saw SK-SD is operated using a drive unit. Information on connection and on the individual operations can be found in the Operating Instructions of the drive unit.

Example: LH drive unit

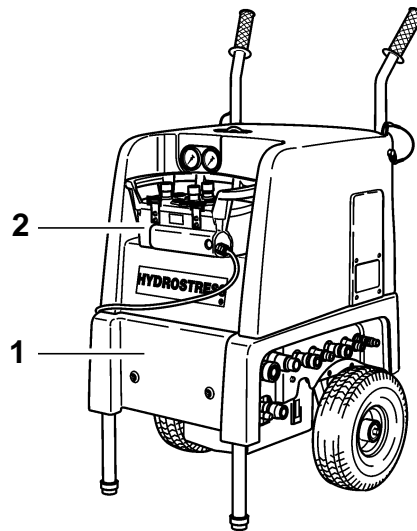

Fig. 5-1 Drive unit with remote control

- 1 Drive unit LH
- 2 Remote control

## 5.1.5 Safety-related operator's controls

### 5.1.5.1 Diamond wire guard

The diamond wire guard is a safety device. It provides protection from accidental contact with the cutting tool and from flying parts and at the same time acts as a spray guard. Working without the diamond wire guard is prohibited.

### 5.1.5.2 Emergency Stop pushbutton

Example: LH drive unit remote control

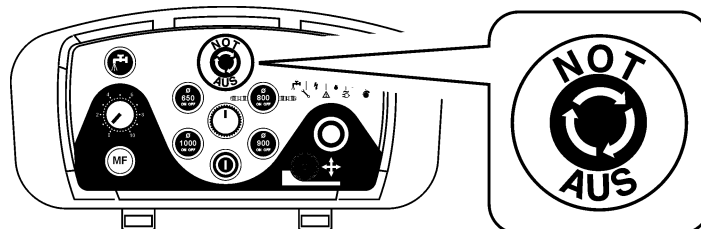

Fig. 5-2 Emergency stop

In danger situations the Emergency Stop pushbutton must be pressed immediately. Pressing the Emergency Stop pushbutton immediately halts the system and prevents the system being accidentally switched on again.

### 5.1.6 Application

#### 5.1.6.1 The correct cutting direction

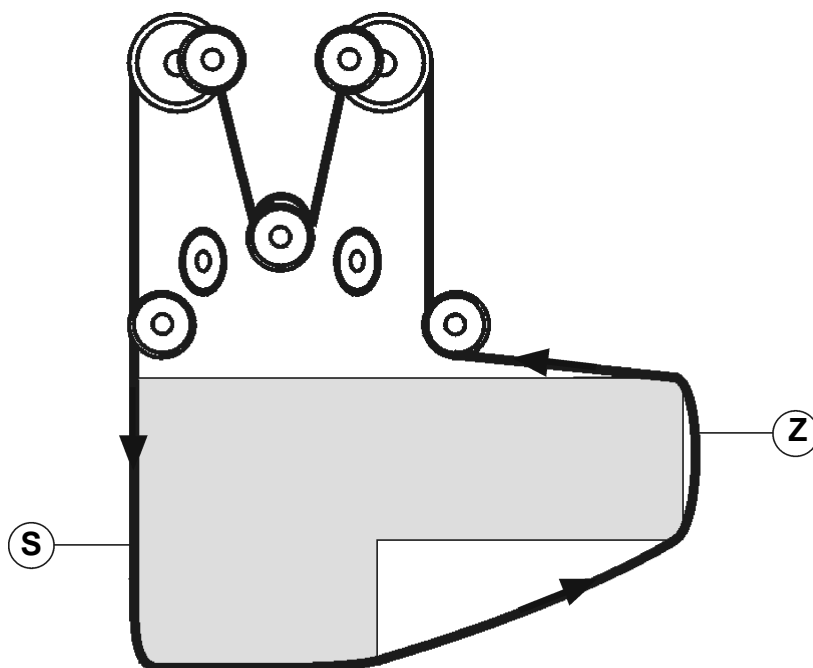

Fig. 5-3 Cutting direction

- Z Taut side
- S Slack side



<b>Information</b>	
	<p>The saw cut should be carried out with the taut side (Z) of the diamond wire, since this provides the best cutting conditions. Therefore, only cut with the slack side (S) of the diamond wire if the Wire saw SK-SD cannot be positioned in any other way.</p>

### 5.1.6.2 Finishing the cut

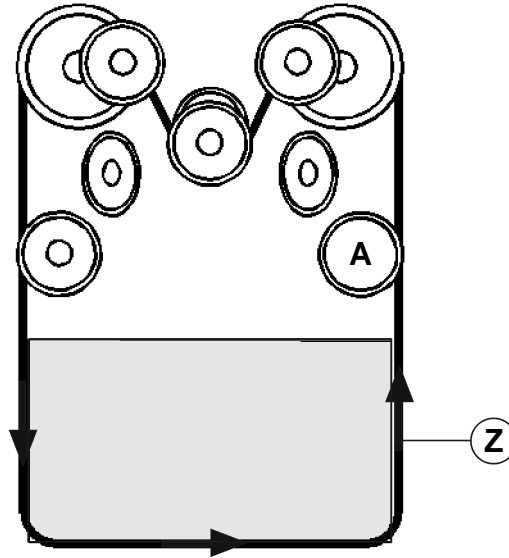

Fig. 5-4 Finishing the cut

- A Swivel roll on taut side
- Z Taut side of diamond wire

During the finishing cut the swivel roll (A) must be swivelled inwards at the tensioned side (Z) so that the diamond wire can be caught by the swivel rolls at the end of the cut.



#### Information

Towards the end of a cut, a reduced feed force should be used. This measure makes it possible for the swivel rolls to catch the diamond wire perfectly upon the exit of the diamond wire.

## 5.2 Troubleshooting

Proceed systematically when looking for the causes of a fault. When searching for and correcting faults, use the troubleshooting table in the "Diamond wire saws Safety Manual / System Description".



### Information

The troubleshooting tables can be found in Chapter 6 of the "Wire saws Safety Manual / System Description".

If you are unable to remedy a fault, please call our service centre (see Manufacturer's address: ☎-II on the back of the title page).

To guarantee a rapid and professional solution to the problem, it is important that you have prepared as follows before calling:

- Try to describe the fault as accurately as possible
- Note the type and index of your system components (see name plate)
- Have the Operating Instructions close to hand

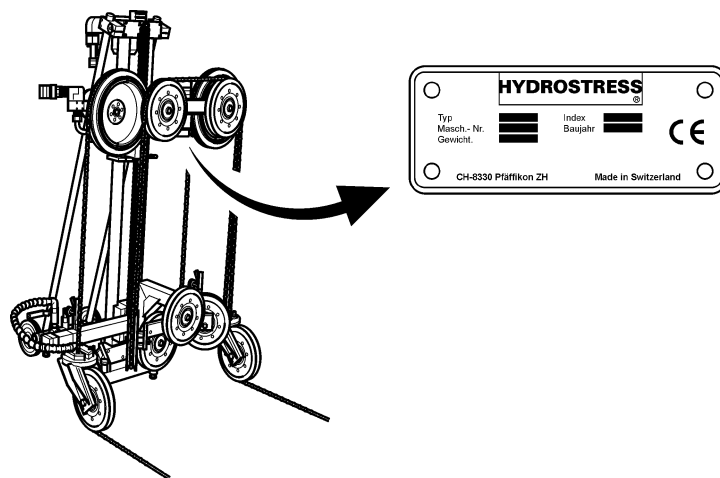

Fig. 5-5 Name plate

### 5.3 Putting into operation

The wire saw SK-SD is supplied ready for use. That which is described under Operation in the "Diamond wire saws Safety Manual / System Description" also applies to the putting into operation of the wire saw SK-SD.



#### Information

Information on operation of wire saws can be found in the "Diamond wire saws Safety Manual / System Description" Chapter 6.



## 6 Servicing and Maintenance

### 6.1 General

Before proceeding, first of all read Chapter 2 "Safety instructions", 2-1 in these Operating Instructions. Be sure also to take note of all the danger information given here and follow the instructions on how to avoid physical injury and damage to property.

#### 6.1.1 Safety instructions

It is essential to observe the following safety instructions, in particular in relation to the servicing and maintenance of the wire saw SK-SD.



### Danger

**Danger of falling heavy parts.**

**When performing the types of work described in this chapter, it is absolutely essential to wear the following personal protective equipment: helmet, goggles, protective gloves and safety shoes.**

**It is essential that the work instructions and procedures described in these Operating Instructions are followed.**

**Failure to observe this regulation may lead to serious physical injury, possibly even death, and to property damage.**



### Warning

**Danger from uncontrolled movements of the wire saw SK-SD.**

**Never connect or disconnect hoses when the wire saw SK-SD is running.**

**Failure to adhere to this regulation may result in physical injury and damage to property.**

### **6.1.2 Personnel qualifications**

The wire saw SK-SD should not be maintained by unauthorised persons. Personnel are only authorised where they meet the following requirements:

- Has trained as a concrete cutting expert or completed a technical course from the regional professional association and federation or has professional experience.
- Has received an introduction (basic training) about operating the wire saw SK-SD from a service engineer.
- Has read and understood chapter 2 "Safety instructions".

## 6.2 Maintenance and servicing table

The following maintenance work must be performed according to the prescribed cycles. Wear parts that are not subject to particular maintenance intervals should also be checked regularly for wear and adjusted or exchanged as necessary.

Maintain the system within the indicated intervals in order to ensure:

- Safety for the user
- Optimum performance
- Optimum reliability at all times

		before every start-up	upon completion of work	weekly	annually	in the event of malfunctions	in the event of damage
Wire saw SK-SD	Lubricate and retighten accessible screws and nuts			X		X	X
Drive rolls and guide rolls	Check bandages for wear, see "Chapter 6" 6.2.1, 6-4	X				X	X
	Check bearings			X		X	X
When there is risk of frost	Blow out water lines		X			X	X
Guide support	Check wear and setting of the guide elements	X	X			X	X
Chain	Monitor and lubricate			X		X	X
Adjustable feet	Monitor and lubricate			X		X	X
Hoses	Check for cleanliness / damage	X	X			X	X
Feed motor	Check for cleanliness / damage	X	X			X	X
Drive motor	Check for cleanliness / damage	X	X			X	X
Diamond wire	Water cleaning		X				
	Check for wear	X	X			X	X
Major service	May only be carried out by TYROLIT Hydrostress AG or an authorised representative				X		

## 6.2.1 Bandaging drive and deflection pulleys

### 6.2.1.1 Drive pulley bandages

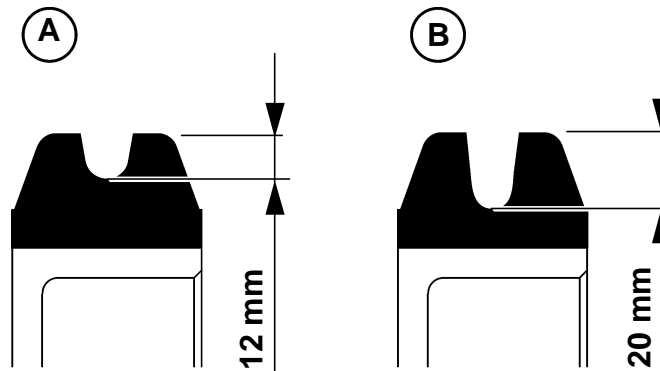

Fig. 6-1 Drive pulley bandage

- A New bandage
- B Worn bandage

#### When does a roll have to be replaced?

The roll must be replaced when the dimension between the outside edge of the bandage and the bottom of the groove is greater than 20 mm.

### Warning



#### Risk of accident from worn bandages.

In the case of excessive wear, the correct locking of the bandage in the rim can no longer be guaranteed. The bandage can detach and be thrown off.

Replace the drive pulley in good time.

Failure to adhere to this regulation may result in physical injury and damage to property.



### Information

In order to increase the service life of the drive pulley bandage, the drive pulley at the taut side can be switched with the drive pulley at the slack side when the bandage is half worn.

6.2.1.2 Deflection pulley bandages

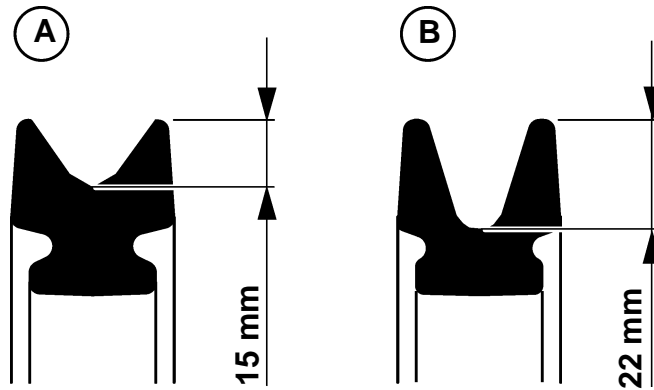

Fig. 6-2 Deflection pulley bandage

- A New bandage
- B Worn bandage

**When must a bandage be replaced?**

The bandage must be replaced when the dimension between the outside edge of the bandage and the bottom of the groove is greater than 22.

**Warning**



**Danger from worn bandages.**

**In the case of excessive wear, the correct clamping of the bandage in the rim can no longer be guaranteed. The bandage can detach and be thrown off.**

**Replace the bandages in good time.**

**Failure to adhere to this regulation may result in physical injury and damage to property.**

## 6.2.2 Tension the chain

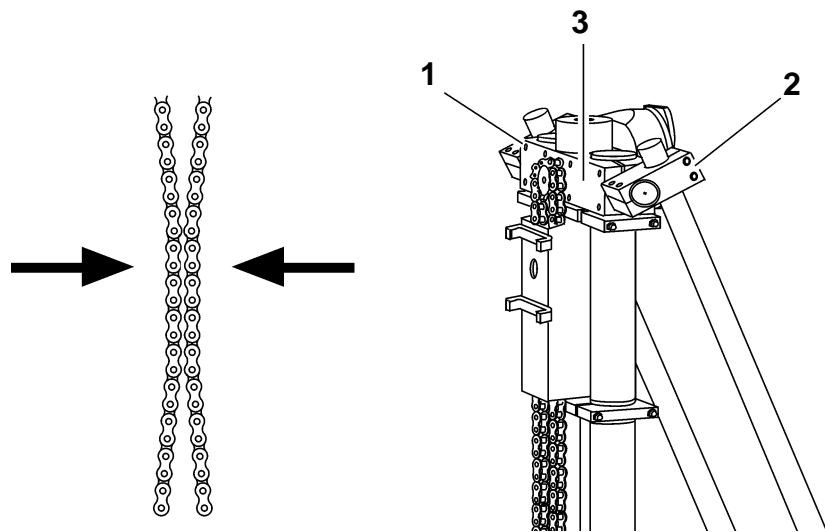

Fig. 6-3 Tensioning chain

- 1 Guide carrier fastening screws
- 2 Guide carrier
- 3 Support rod fastening screws

Proceed as follows:

- Undo the 4 screws (1) of the upper guide carrier
- Undo the 4 screws (2) of the two support rods
- Push the guide carrier (3) upwards until the chain is taut



### Information

The chain is correctly tensioned if the chain links just about touch in the middle if they are pushed together by hand.

### 6.2.3 Adjusting the support clamp

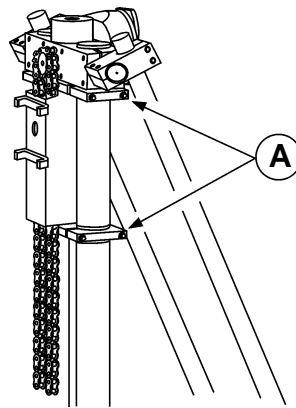

Fig. 6-4 Adjusting the support clamp



#### Information

The clamp and the guide characteristics of the support can be adjusted using the 8 screws (A).

## 6.3 Warranty

TYROLIT Hydrostress AG Guarantees that the system supplied is free from material and manufacturing defects. For the undertaking of warranty services by TYROLIT Hydrostress AG - in international sales under the express exclusion of the warranty regulations of the UN law on sales of 11 April 1980 - the following conditions apply:

1. Any warranty claims must take place within 12 months from hand-over. Any undertaking of warranty service does not extend this time limit.
2. The system and/or any affected part(s) must be sent for repair or replacement immediately a defect is discovered to TYROLIT Hydrostress AG or a local authorised TYROLIT Hydrostress AG branch office.
3. This warranty covers the free of charge repair or free of charge replacement of defective parts. No undertaking of warranty over and above this exists.
4. Parts that are normally subject to wear and tear are not covered by this warranty.  
For wearing parts regulations see "Chapter 6" 6.4, 6-9.
5. The warranty service is only undertaken provided that the system has been correctly used, handled, serviced and cleaned in accordance with the Operating Instructions and the technical integrity is preserved, i.e. that only original TYROLIT Hydrostress AG consumable material, accessories and spare parts have been used with the system.
6. Further claims are excluded. In particular, TYROLIT Hydrostress AG shall not be liable for direct or indirect damages, losses or costs associated with the use of the system.
7. The warranty expires immediately if the system or only one individual component of it is in any way converted, changed or modified.
8. Provided that a special written contract was concluded for the system, any warranty agreements established therein shall apply. Any verbal or implicit warranty agreements are invalid.



## 6.4 Wearing parts

### 6.4.1 Wearing part regulations

Wearing parts are those parts which are subject to operational wear and tear when the machine is used correctly. A uniform definition of wear is not possible as this will differ according to the intensity of use. Wearing parts must be maintained, adjusted and, if necessary replaced differently for each system according to the Operating Instructions of the manufacturer. Operational wear and tear cannot justify a warranty claim.

**Wear parts:**

- feed and drive elements such as toothed racks, toothed wheels, pinions, spindles, spindle nuts, spindle bearings, wire, chains, chain wheels and belts,
- seals, cables, hoses, collars, connectors, couplings and switches for pneumatics, hydraulics, water, electricity and fuel
- guide elements such as guide beads, guide bushes, guide rails, rollers, bearings and anti-slip supports
- clamps of quick-release system
- flushing head seals
- friction and anti-friction bearings that do not operate in an oil bath
- shaft sealing rings and seals
- friction and overload couplings, brake device
- carbon brushes, collectors
- easy release rings
- adjusting potentiometers and manual control elements
- fuses and lamps
- auxiliary and operating resources
- anchoring elements such as dowels, tie bolts and screws
- floor coverings
- lamellas
- membranes
- spark plugs, glow plugs
- parts of the reversing starter such as starting cord, starting handle, starting roller, starting spring
- sealing brushes, rubber seals, splash guards
- filters of all kinds
- drive and diverter rolls, bandages
- wire movement guards
- running and drive wheels
- water pumps
- cutting spoil transport rollers
- drilling, parting-off and cutting tools

